

1. The instructions refer only to the proper installation of the drain and do not contain information on waterproofing other components of the shower enclosure.
2. The installation instructions presented are based on waterproofing made in the form of liquid foil.
3. It remains up to the flooring contractor to determine whether the bonded liquid film is suitable as a substrate for the applied flooring (stiffness/hardness, adhesion, etc.). If the flooring contractor determines that this waterproofing system is not suitable, e.g., it is too flexible, then he should use a waterproofing system suitable for the floor.

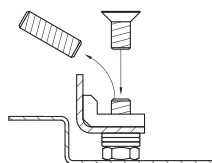

1. Check that the distance of the top edge of the frame to the waterproofing flange corresponds to the assumed thickness of the floor covering. Leave an additional 2mm for the waterproofing layer. If necessary, correct the height with the adjustment kit included with the product.



2. Attach the adjustment feet to the bottom of the gutter. Fix the feet to the ground. Adjust the height and level the top edge of the frame about 1-2mm below the finished surface.

We recommend leaving the foil on the decorative grate.

Connect the drain to the drainage system, check for leaks and again check the position of the upper edge of the frame.



3. Fill the surface under and around the outlet with floor screed up to the level of the gutter flange, maintaining an appropriate slope.



4. Cover the flange and the surrounding area with an insulating foil in a liquid form.



5. Unfold the membrane and slightly press it to the liquid foil to ensure close adherence.

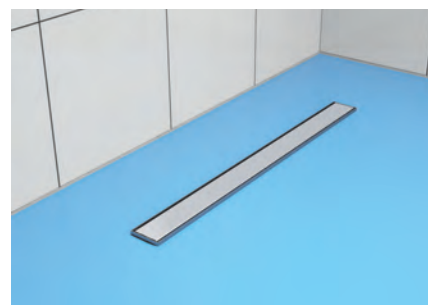

6. After the first layer has dried, apply another layer of liquid foil agent onto the entire surface, including over the membrane.



7. After waiting the recommended amount of time by the manufacturer for the liquid foil (tanking system) to dry, proceed to apply the chosen floor finish material.

Warranty terms and conditions

1. The warranty is the manufacturer's, namely Wiper sp. z o.o. company, pledge to repair/replace free of charge any physical defects of the product. The warranty period, 25 years, is counted from the date of purchase indicated on the invoice or receipt.
2. The manufacturer guarantees that the purchased product was manufactured in accordance with the approved design, has the properties specified in the product data sheet and is free of defects, has technical parameters specified for this type of product and meets the standards set out in the Declaration of Conformity.
3. Proof of purchase - invoice, receipt must be provided to receive warranty service.
4. The warranty is granted to a person/company indicated on the invoice.
5. The present warranty will not cover the products damaged as a result of:
 - 5.1 – improper handling or operation and maintenance outside the product's specifications,
 - 5.2 – mechanical damage to the product after purchase, during transportation or storage
 - 5.3 – installation contrary to the installation instructions recommended by the manufacturer, an attempt to make technical change or an attempt to interfere with the structure and integrity of the product after its purchase, as well as use of the product after stating its malfunction
 - 5.4 – using chemical agents not covered by the resistance for the material bearing 0H18N9/0H18N10 symbol pursuant to the European Standards EN10088-1, EN10088-2, EN10088-3
 - 5.5 – damage caused by fortuitous events and natural disasters.
6. The warranty applies to the product purchased and does not include the right to seek reimbursement or payment for the damages caused by malfunction of the product, which can be settled only through the court pursuant to the relevant applicable law.
7. Wiper Company undertakes to consider the warranty claim within 14 working days after its registration.
8. Should the claim be accepted, the manufacturer will replace the entire product or its defective part within 14 working days from accepting the claim. The decision of which option to choose lies with the manufacturer and does not require the consent of the claimant.
9. Any warranty claims must be made with the Seller of the product.

Diagram of various parts

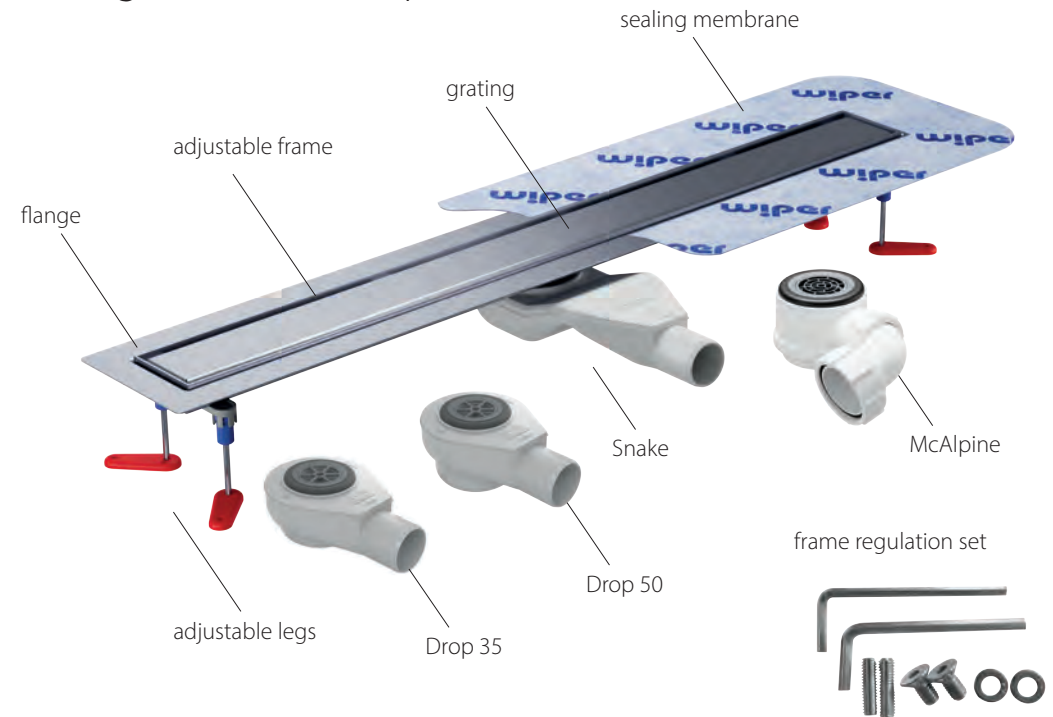

Technical drawing of the adjustment height

